

Apex Pro X1

DP1350

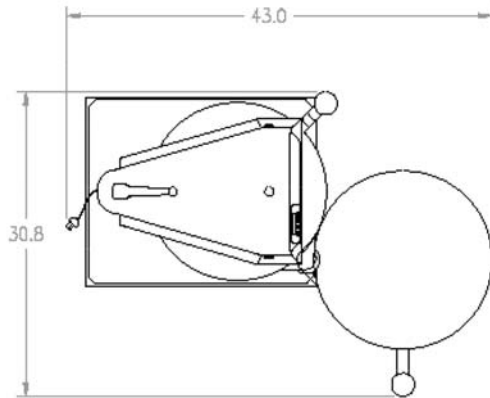

TOP VIEW

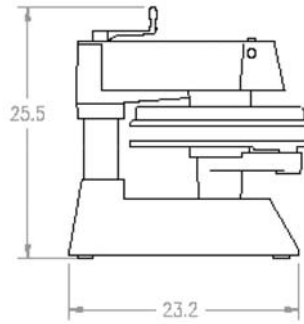

LEFT SIDE VIEW

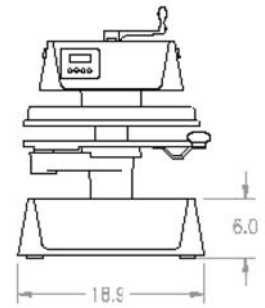

FRONT VIEW

Equipment Details

Temperature Control	Yes	Pies Per Hour	250+
Maximum Heat	0 - 450F	Shipping Weight	202lbs/91kg
Programmable Timer	Yes	Machine Weight	169lbs/76kg
Thickness Control	Yes	Voltage	120/208/220/240
Power Cord Length	72"	Wattage	1500
Plug	NEMA 6-15P	Amps	12.5/6.8/6.3



PROLUXE™

CORPORATE HEADQUARTERS
20281 HARVILL AVE. PERRIS, CA 92570

HELPING COMMERCIAL KITCHENS
PRODUCE GREAT FOOD FASTER

ADVICE AND SUPPORT
1-800-624-6717

Efficient and Automatic Dough Forming

This versatile dough press is perfect for high volume kitchens looking to press anything from pizzas and bread to fortune cookies and tortillas.

Its dual heat and manual operation gives operators the flexibility and consistency required to form a variety of dough products.



Apex Pro X1

Hydraulic Dough Press
DP1350



Consistent Pizza

We designed this machine for the demanding kitchens looking to produce fresh dough fast enough for the most high-volume operations.



250-300 PIZZAS PER HOUR



HEATED UPPER PLATEN LIFETIME LIMITED WARRANTY



NO COMPRESSOR REQUIRED



FULL AUTOMATED